

BAGMASTER® 400 VFFS BAGGING MACHINE

The **Bagmaster®** 400 Vertical Form Fill and Seal Bagging Machine is a state of the art, high speed bagging system that makes bags out of flat stock film, with the bag formed around the product. It is designed and engineered for use in food and non-food applications and uses polyethylene and supported clear or pre-printed films. The 400 machine can be integrated with **Batchmaster®** Counters or **Weighmaster®** scales to form a turnkey packaging system.

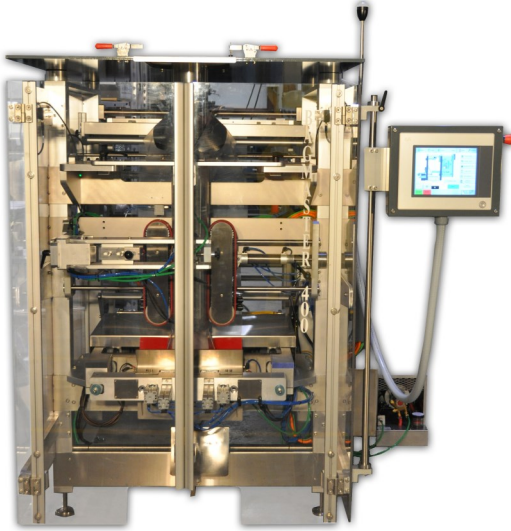

Bagmaster® 400 Bagger

Bagmaster® 400 Benefits:

Flexibility - run a variety of film, including polyethylene, laminate, and Kraft/poly film structures, impulse seal wires or constant heat option

Versatility - system integration to any type of packaging machine. Designed for short or long production runs

Durability - specifically designed for heavy duty applications. Utilizing 30 years of experience in frozen food, hardware, toy and industrial product applications

Speed—run up to 85 cycles per minute

State of the art electronics - controls architecture implemented in accordance with PackML and PackML Tags to provide standardized integration of upstream and downstream equipment. Includes a standard 10.4" operator friendly color touch screen

Ergonomics - low overall height and easy access to interior of machine

Cost Savings - produces bags from flat web material, typically providing cost savings of approximately 75% when compared to using pre-made bags

Value—increased output for all your packaging needs, resulting in cost effective, efficiently filled packages

Bagmaster® 400 Features:

- Configured to meet NEMA 12 (IP52) standards
- Constant / resistance heat sealing system
- Electrical synchronization for dosing system (weigher, counter, auger, etc.)
- Forming set for one bag size; various bag styles available
- Machine control via 10.4" color touch screen. Includes intuitive operator guidance, fault diagnostics with help text for trouble shooting, and production data acquisition. Program memory for 100 production recipes
- Motor powered packaging material unwind at rear of machine controlled via position monitoring of the dancer arm provides material infeed with precise web tension control
- Product-in-jaw feature brings the machine to a stop if the seal bars do not close completely
- Quick-opening pull belt mechanism (pneumatically operated) for ease of material set-up and size change-over
- Robust open frame design provides excellent access to the machine interior
- Semi-automatic web tracking adjustment (left/right correction) via touch screen powered by a DC gear motor
- Servo driven cross jaw and film pull
- Single film reel support with pneumatic film reel spindle
- Web transport system with servo motor driven friction pull belts

BSI BATCHING SYSTEMS, INC.

ENGINEERED AUTOMATED PACKAGING SOLUTIONS

Applications: Hardware, Plastic, Toy, Hobby, Chemical, Electronic, Medical, Pharmaceutical, and many more

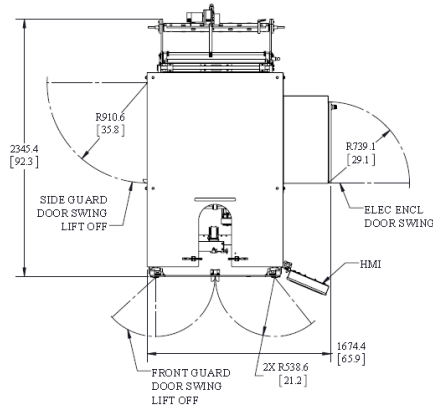

Machine Footprint—Top View

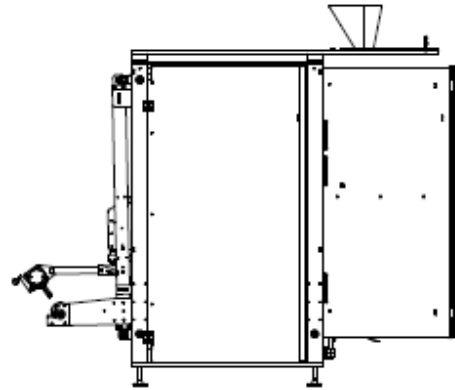

Machine Footprint—Side View

Technical Specifications:

Machine Dimensions

Width: 1,354mm (53")
 Depth: 2,525mm (99.5") - with max. \varnothing film roll
 Height: 1,443mm (57")

Package Dimensions

Flat bag: width min. 75mm (3.0"), max. 400mm (15.75")
 Stand-up: width min. 50mm (2.0"), max. 350mm (13.75")
 depth 30mm - 140mm (1.2" - 5.5")
 width + depth 400mm maximum (15.75")
 Bag length: 75mm - 510mm (3" - 20")

Machine Speed*

Up to 85 cycles per minute
 *speeds are product and film dependent

Air Consumption*

8 SCFM @ 80 PSI
 *will vary based on options

Pneumatics

Festo valve bank operated via field bus

Machine Weight

Approximately 1,400 lbs.

Packaging Material

Film width: 840mm maximum (33")
 Outside roll diameter: 508mm maximum (20")
 Roll core diameter: 73-77mm (3")

Power Consumption

220/480/575V, 1PH, 60Hz or
 220-575, 3PH, 60Hz 7KVA

Machine Control & Operator Interface

Power Panel 500 with Intel Atom Z510 processor
 and 265mm (10.4") color touch screen

Proximity Sensors

Operated via field bus

Bagmaster® 400 Standard Options:

programmable warning beacon; automatic web tracking; side gusset device; flat-bottom bag device; tear notch device for easy bag opening; hole punch (round, sombrero, etc.); poly seal system (impulse); anti-static bar and nozzle options; adjustable bag discharge chute; bag support and eject unit at discharge; gas flush accessories with integrated controls; filling tube dust extraction; air relief film perforator; integration of a variety of thermal transfer printers; additional emergency stop switch at rear of machine; cUL listed electrical control panel; photoelectric registration mark sensor; air expeller; product catch plates mounted atop cross seal jaws; product drip pan above machine; frame extensions to increase machine height